

GSTIN: 24DCAPP9328H1ZG

Ankur Patel
Mo:9726923885

UMA PHARMATECH MACHINERY

The Feature Of Biotech

Factory Address: 61, Yamuna Industrial Park, Vanch-Dhamatvan Road, Dhamatvan-382435, Gujarat, India

Web: www.umapharmatechmachinerys@gmail.comEmail: umapharmatechmachinerys@gmail.com

REACTOR SPECIFICATION SHEET

Ref: UPM-2023-7045

Date 1 APR, 2023

Customer -

Contact -

Project

ITEM 5 KL mixing vessel

Vessel Details

Capacity	5 KL
Diameter	1800 mm
Straight Height (T.L TO T.L)	2000 mm
Shell (cylindrical)	08 mm thk SS304
Top Dishend (10% torispherical)	10 mm thk SS304
Bottom Dishend (10% torispherical)	10 mm thk SS304

Lug-Ms

Manhole:- 450 NB

Nozzles:- Flanges:- Standard Flange, 150 Class

Pipe:- SS304, Sch 40, Seamless

Surface finish:- Acid cleaned

Design Criteria

Viscosity	100 cP	SG	2
Pressure	FV TO 5 Kg/cm ²	Temp	120 deg C

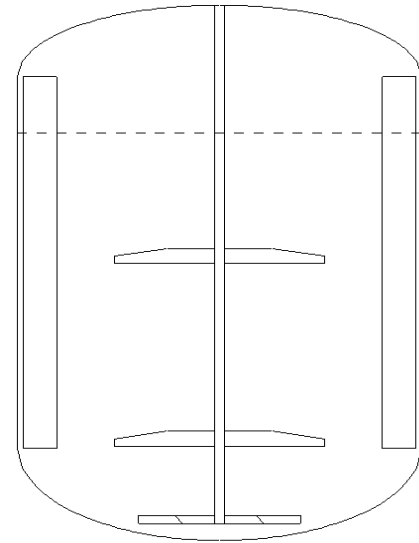

Mounting PAD/Flange Size 12" NB

Sealing (Hi-fab/Leakproof/Eqv.) UPM Standard Stuffing Box With PTFE Glane Packing

Gearbox (Bonfiglioli) In-line helical, AS-45 F19.99 P112 B5V1 (S.F-1.4)

Motor (Crompton/BBL/Hindustan) 5 Hp Non FLP, IE2, 4 Pole, Flanged, 3 Ph, 415 V, 50 Hz

Impeller Type (From bottom) Pitch Tickler Hydrofoil Hydrofoil

Impeller Sweep 810 mm 1000 mm 1000 mm

Baffle Recommendation 4 nos @ 90degree apart 150 mm wide and 25 mm off wall

Agitator Details

Model #		5@70/304SB75	
Mixing Intensity	8 (Vigrous Mixing)	Shaft Diameter	75 mm
Pumping Capacity	39.5 M3/min	Shaft Speed	70 RPM
Tip Speed	3.66 m/sec	MOC Contact Parts	SS 304
Critical Speed	190 RPM	MOC Non-CP	MS/CS

Scope of Supply

Design, manufactur, supply and after sales service of UPM make vessel with agitator assembly. Which includes impeller blades with hub, shaft, lantern assembly with bearing housing and seal, gearbox, motor etc.

Commercial Terms & Conditions

Unit Price	Info@umapharmatechmachinery.com
Price Basis	Ex Works
Taxes & Duty	Extra as applicable at the time of dispatch, Presently GST = 18%
Packing & Forwarding	2% Extra
Freight & Insurance	By purchaser
Delivery	10 to 12 weeks after drawing approval
Payment Terms	50 % advance including GST, balance against proforma invoice before dispatch